

INTORQ

setting the standard



Electromagnetic clutches and brakes

INTORQ 14.105 und 14.115

7.5 – 480 Nm

www.intorq.com

We set the standards

The INTORQ brand stands for reliable brake solutions with the highest product standards. INTORQ products are used in a very diverse range of applications, from brake motors and industrial trucks to hoists, cranes and wind turbines. We can create the right solution for you and your drive – individually and reliably.

The INTORQ module system offers numerous variants that can be used in many motors and geared motors, setting standards worldwide. We have been increasing our international presence step by step, establishing sites in Shanghai, Atlanta and Pune. So our network of sales and service staff is close at hand all over the world, ready to support you.



INTORQ at a glance

- Electromagnetic brakes and clutches
- Flexibility with standard options as well as customised solutions
- Centralised product development and production located in aerzen
- Fast response and delivery times globally thanks to production and warehousing in Shanghai, Atlanta and Pune.
- Over 50 million euros a year sales volume
- 800,000 units a year
- 13,000 square metres production area
- 250 employees
- Market leader with 63 sales partners in 49 countries



Versatile and really reliable

INTORQ electromagnetic clutches and brakes transmit the drive torque or braking torque by friction in dry running conditions. When the DC voltage is applied, torque transmission is achieved free from torsional backlash. The prestressed annular spring on the armature assembly ensures release without residual torque on de-energisation.

The clutches and brakes can be used in any mounting position and are virtually maintenance-free. Depending on the friction energy used, the working air gap only needs to be checked (and corrected if necessary) at specific time intervals. Special machining of the friction surfaces ensures that the rated torques can be achieved after very few switching operations without a run-in period.

The catalogue will help you to select and order the electromagnetic brake and/or electromagnetic clutch you need.

This catalogue contains:

INTORQ 14.105 and INTORQ 14.115 with transmitted torques 7.5 – 480 Nm

Example applications

- Packing machines
- Automation technology
- Gate drives
- Folding and printing machines



Automation technology



Printing machines

Product key

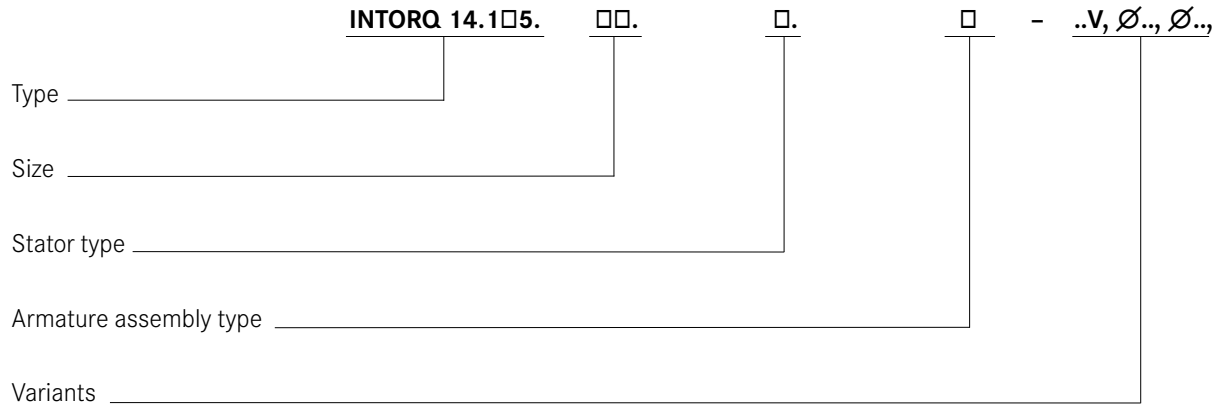

Type

- 14.105 electromagnetic clutch
- 14.115 electromagnetic brake

Size

06, 08, 10, 12, 16, 20, 25

Stator type

- 1 - Flange-mounting type
- 3 - Type with bearings

Armature assembly type

- 1 - With external flange hub
- 2 - With internal flange hub (for brakes only)
- 3 - Without flange hub
- 5 - With flange hub on bearings (for clutches only)

Variants

- Supply voltage
- Rotor bore
- Armature assembly bore



Electromagnetic clutch
INTORQ 14.105.□□.1.5



Electromagnetic brake
INTORQ 14.115.□□.1.2



Electromagnetic brake
INTORQ 14.115.□□.1.1



Electromagnetic clutch
INTORQ 14.105.□□.3.1

Contents

Product key	4	Accessories	
List of abbreviations	5	Transformer switch	19
Product information	6	Spark suppressor	20
		High-speed switchgear	21
Selection		General information	
Dimensioning	8	for assembly	22
Permissible switching energy/ operating frequency			
Calculation example.....	9		
Technical data			
Selection table	10		
Flange-mounted and shaft-mounted			
electromagnetic clutches.....	11		
electromagnetic brakes	17		

List of abbreviations

P	[W]	power	Sh_{max}	[1/h]	Maximum permissible operating frequency, depending on the friction work per operation
P_N	[W]	Rated coil power at rated voltage and 20°C	Sh_{ue}	[1/h]	transitional operating frequency, thermal rating of the brake/clutch
J_{Lres}	[kgm ²]	moment of inertia of the load referred to the brake shaft	SLN	[mm]	Rated air gap
U_N	[V DC]	Rated coil voltage	t₁	[s]	Engagement time, the total of the reaction delay and torque rise time $t_1 = t_{11} + t_{12}$
M_a	[Nm]	deceleration torque	t₂	[s]	Disengagement time, time from switching the stator until the torque has reduced to 0.1 M _K
M_{erf}	[Nm]	required braking torque	t₃	[s]	Slipping time to standstill (after t ₁₁)
M_K	[Nm]	Rated torque of the brake at a relative speed of 100 r/min	t₁₁	[s]	Delay time when connecting, time from disconnecting the voltage until the torque begins to rise
M_L	[Nm]	Load torque, torque that the static load produces at the motor shaft	t₁₂	[s]	Rise time of braking torque, time from beginning of rise of torque until braking torque is reached
Δn₀	[r/min]	Initial relative speed of the brake			
Q	[J]	Heat/energy			
Q_E	[J]	Maximum permissible friction work per switching cycle, thermal rating of the brake			
Q_{smax}	[J]	maximum permissible friction work during cyclic switching, depending on the operating frequency			
Sh	[1/h]	Operating frequency, the number of repeated operations per unit time			

Product information

Electromagnetic clutches and brakes are used wherever rapid acceleration or deceleration of masses in motion is required.

This document describes powerful and reliable mass-produced products which have already been tried and tested in numerous applications.

A complete range

- 7 sizes
- Clutch/braking torques from 7.5 – 480 Nm

Versatile

- Suitable for any mounting position
- Clutches can be supplied as flange-mounted or shaft-mounted versions
- Various armature assembly types for clutches and brakes can be supplied to suit any application case

Torque transmission

- Friction transmission in dry running
- Immediately ready for operation
- Special machining of the friction surfaces ensures that the rated torques are achieved after very few switching operations without a run-in period, even when the product is new.

Reliable

- The certified ISO 9001 and ISO 14001 quality system provides the basis for consistently high-quality products
- Manufacture and testing to VDE 0580

Low maintenance

- Working air gap only has to be checked in relation to the friction energy used
- Wear adjustment only required at 2.5 times the rated air gap
- Asbestos-free friction linings with a low rate of wear and nitride hardened armature plates ensure a long service life and constant torques

Release without detent torque

- The prestressed annular spring on the armature assembly ensures release without residual torque on de-energisation

Short and consistent operating times

- The prestressed, backlash-free annular spring on the armature assembly enables short and constant operating times to be achieved, even with larger working air gaps

Options

- Special voltages and bores are available on request

Produktinformationen

Principle of operation

To generate the drive torque or braking torque, the stator coil is supplied with DC voltage and a magnetic field is generated. The magnetic attraction force pulls the armature plate on the armature assembly against the force of the prestressed spring across the air gap and towards the friction surface of the brake armature or rotor, thereby making torque available.

If the voltage supply is interrupted, the magnetic field will collapse and the prestressed annular spring will pull the armature plate back to its initial position.

Flange-mounted brakes

INTORQ 14.115.□□.1.□

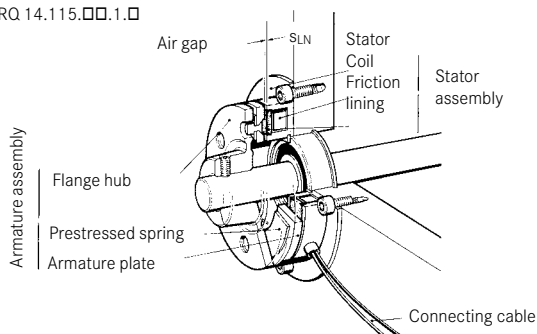

Flange-mounted clutches and brakes

The stator and flange should be mounted centrally on the shaft. Two tolerated diameters are available for this purpose.

The clutch rotor is mounted on the shaft using a keyway connection and secured against axial movement. Mounting dimension "b" under "Dimensions" must be observed exactly.

Flange-mounted clutches

INTORQ 14.105.□□.1.□

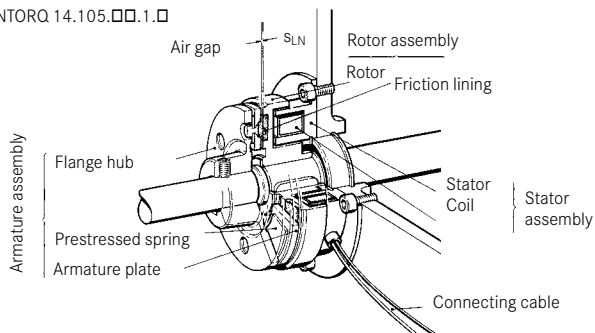

Shaft-mounted clutches

If a suitable mounting surface for the flange stator is not available, a shaft-mounted clutch should be used. The stator is supported on the rotor. A pin, which engages in the anti-rotation tag with sufficient clearance, simply has to take up the bearing friction.

Torque is transmitted via a keyway connection as on flange-mounted clutches.

Armature assemblies

Type 1, 2 and 5 armature assemblies should be mounted on the shaft and secured against axial movement following precise setting of the working air gap $sL\ddot{u}$ (see Dimensions). Armature assembly type 3 should be screwed to the element to be decelerated or accelerated (e.g. belt pulley) using the annular spring. See page 22 for the screws and lock washers to be used. Please make sure that the clearing holes for the rivet heads on the armature assembly are sufficiently large, so that the axial movement of the armature assembly is not restricted.

Shaft-mounted clutches

INTORQ 14.105.□□.3.□

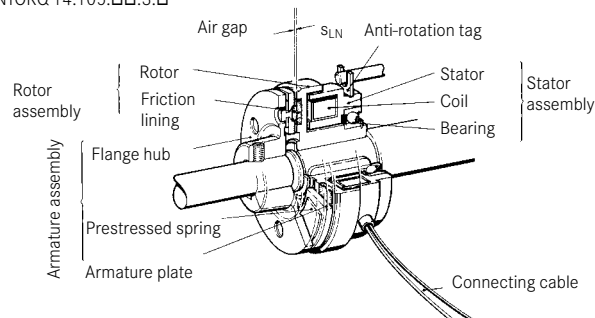

Selection

Dimensioning

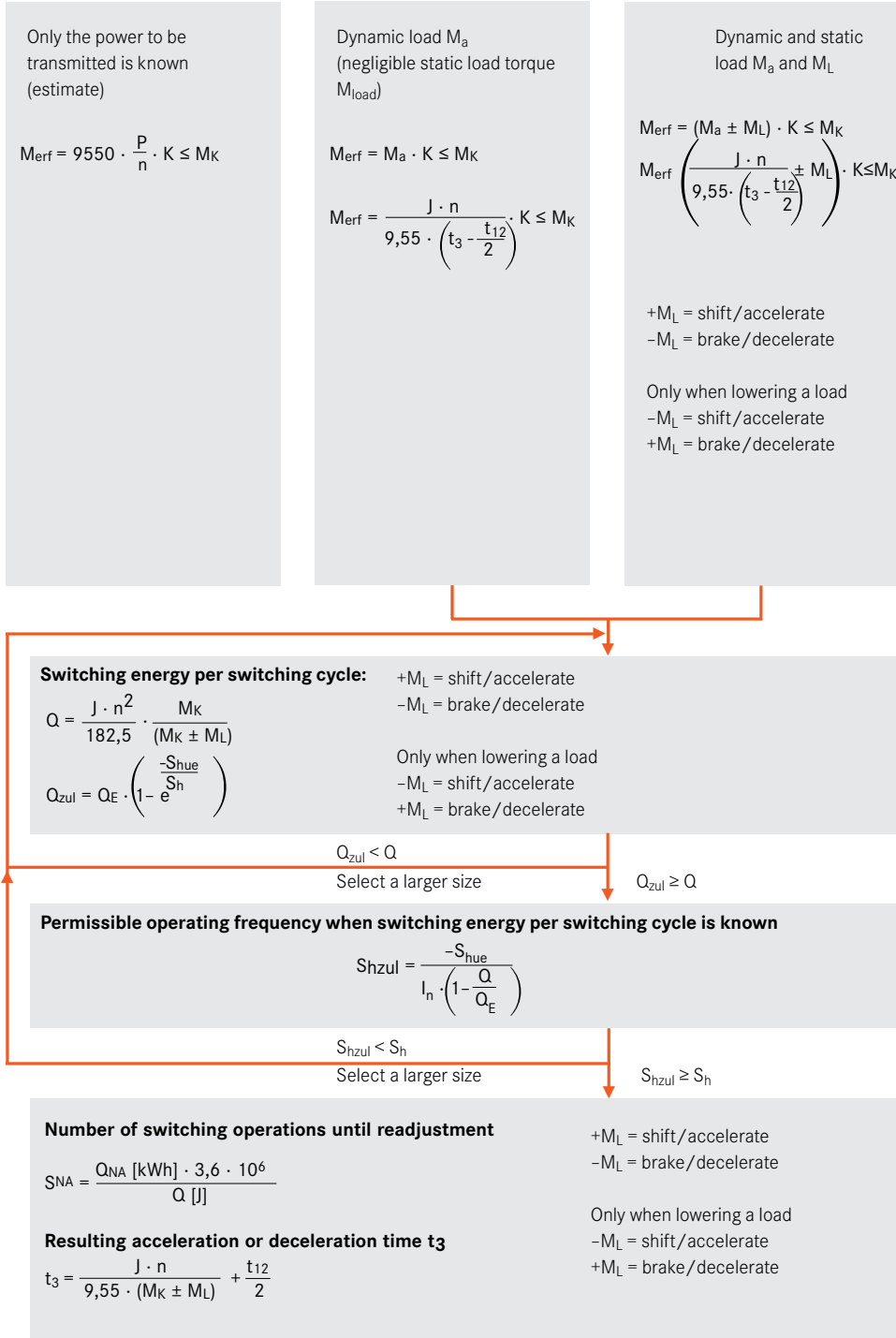

Operating data calculation

Q_{NA} is indicated in the Technical data

Determining the size by specifying the required torque M_{req}

Parameters included in the calculation are moments of inertia, relative speeds and acceleration or deceleration times.

K is a safety factor to ensure transmission security even in extreme operating conditions. K is dependent on the prevailing operating conditions.

K is always ≥ 2

Checking the thermal load

The switching energy per switching cycle Q and the operating frequency S_h determine the thermal load of the clutch or brake. The values calculated or plotted on a graph must not exceed the permissible values for the specific sizes.

Parameters Q_E and S_{hue} are indicated in the Technical data.

Q_{hzul} and S_{hzul} can also be taken from the diagram on page 9 for sizes 06 to 25.

Selection

Permissible switching energy/operating frequency

Electromagnetic clutches

INTORQ 14.105 (7.5 – 480 Nm)

Electromagnetic brakes

INTORQ 14.115 (7.5 – 480 Nm)

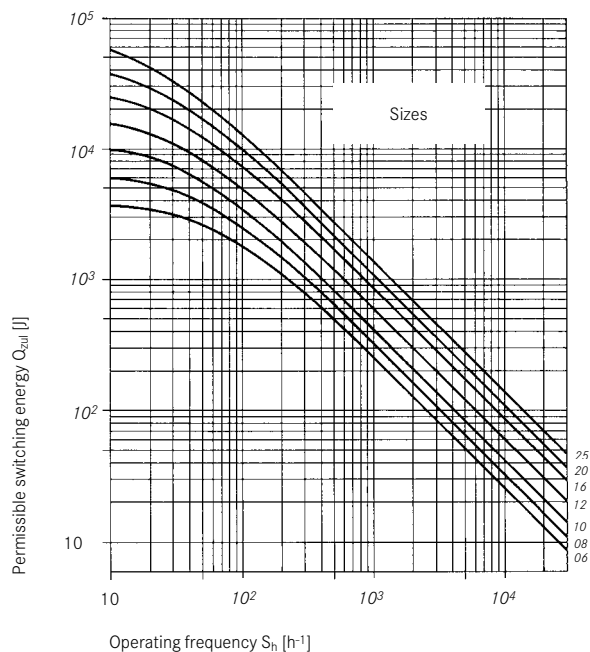

Calculation example

Default parameters:

$$J = 0.01 \text{ kgm}^2$$

$$M_L = 6 \text{ Nm}$$

$$n = 700 \text{ min}^{-1}$$

$$t_3 = 0.15 \text{ s}$$

$$\frac{t_{12}}{2} \text{ assumed to be } 0.03 \text{ s}$$

$$S_h = 5000 \text{ switching operations per hour}$$

Calculation of the required torque:

$$M_a = \frac{J \cdot n}{9.55 \cdot \left(t_3 - \frac{t_{12}}{2}\right)} = \frac{0.01 \cdot 700}{9.55 \cdot (0.15 - 0.03)}$$

$$M_a = 6.1 \text{ Nm}$$

$$M_{\text{erf}} = (M_a + M_L) \cdot K = (6.1 + 6) \cdot 2$$

$$M_{\text{erf}} = 24.2 \text{ Nm}$$

Electromagnetic clutch selected:

INTORQ 14.105.10.1.1 with

$$M_K = 30 \text{ Nm}$$

Calculation of the switching energy per switching cycle:

$$Q = \frac{J \cdot n^2}{182.5} \cdot \frac{M_K}{M_K - M_L}$$

$$Q = \frac{0.01 \cdot 700^2}{182.5} \cdot \frac{30}{30 - 6}$$

$$Q = 33.6 \text{ J}$$

Check of the permissible operating frequency:

See the diagram (above) for S_{hzul} depending on the calculated switching energy.

For the selected size (10), the required operating frequency is permissible at the calculated switching energy.

Result:

The selected electromagnetic clutch (INTORQ 14.105.10.1.1, $M_K = 30 \text{ Nm}$) can be used for this application.

Technical data

Selection table

Electromagnetic clutches INTORQ 14.105.□□.□□

Size	M_K ¹⁾ [Nm]	n_{max} [min ⁻¹]	P_{20} °C [W]	Operating times ²⁾ [ms]				Q_E [J]	Q_{NA} [kWh]	S_{hue} [h ⁻¹]	J [10 ⁻⁵ kgm ²]				
				t_{11}	t_{12}	t_1	t_2				Rotor, types		Armature assembly, types		
											1	3	1/2	3	5
06	7,5	8000	15	15	30	45	10	$3,6 \times 10^3$	10	72	11,9	13,3	6	4,2	9,2
08	15	6000	20	20	55	75	15	6×10^3	16,6	56	26,5	29,4	17,1	11,8	28,2
10	30	5000	28	25	85	110	25	10×10^3	34,7	43	78	86,6	66,4	47,2	92
12	60	4000	35	35	105	140	40	16×10^3	69,5	37	226	246	180	130	258
16	120	3000	50	45	125	170	50	25×10^3	130,5	36	630	690	633,3	480	868
20	240	3000	68	60	140	200	60	40×10^3	277,7	28	2050	2150	1900	1370	2580
25	480	2000	85	75	155	230	70	65×10^3	555,5	22	5470	5660	4800	3580	7200

Electromagnetic brakes INTORQ 14.115.□□.□□

Size	M_K ¹⁾ [Nm]	n_{max} [min ⁻¹]	P_{20} °C [W]	Operating times ²⁾ [ms]				Q_E [J]	Q_{NA} [kWh]	S_{hue} [h ⁻¹]	J [10 ⁻⁵ kgm ²]	
				t_{11}	t_{12}	t_1	t_2				Armature assembly, types	
											1/2	3
06	7,5	8000	11,5	10	20	35	10	$3,6 \times 10^3$	10	72	6	4,2
08	15	6000	16	15	25	40	20	6×10^3	16,6	56	17,1	11,8
10	30	5000	21	20	40	60	30	10×10^3	34,7	43	66,4	47,2
12	60	4000	28	25	55	80	45	16×10^3	69,5	37	180	130
16	120	3000	38	30	70	100	60	25×10^3	130,5	36	633,3	480
20	240	3000	45	35	80	115	70	40×10^3	277,7	28	1900	1370
25	480	2000	70	40	90	130	80	65×10^3	555,5	22	4800	3580

¹⁾ In relation to relative speed $n = 100$ rpm

²⁾ Mean values for DC switching with rated air gap and warm coil.

Standard voltage 24 V +5%/-10% to VDE 0580

Temperature class B (130°C)

Technical data

Flange-mounted clutches INTORQ 14.105.□□.1.1

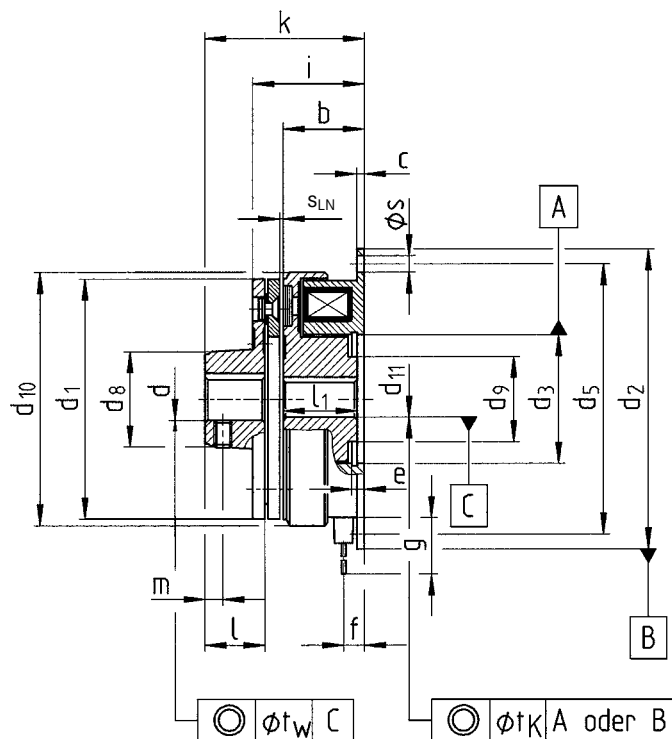

Size	M [Nm]	b	c	d J7**	d H7	d ₁	d ₂	d ₃	d ₅	d ₆	d ₉	d ₁₀	d ₁₁ J7***	d ₁₁ H7
						h8	h9	H8						
06	7,5	24	2	10	10;12;14;15;17	63	80	35	72	27	23	68	10	10;12;14;15;17
08	15	26,5	2,5	10	12;14;15;17;19;20	80	100	42	90	32	28,5	85,5	10	12;14;15;17;19;20;25
10	30	30	3	14	15;19;20;24*;25;28*;30	100	125	52	112	42	40	107	14	15;17;19*;20;22;24;25;28*;30
12	60	33,5	3,5	14	20;24*;25;28*;30;35	125	150	62	137	49	45	134,3	14	20;24;25;28*;30;35;40
16	120	37,5	4	20	25;28*;30;35;38*;40;45;50	160	190	80	175	65	62	170	20	25;28;30;35;38*;40;45;50
20	240	44	5	25	30;35;38*;40;42*;45;50;55;60*	200	230	100	215	83	77	214,3	25	35;38;40;42*;45;50;55;60;65
25	480	51	6	25	40;45;50*;55;60;65*;70;80*	250	290	125	270	105	100	266,5	25	40;45*;50*;55*;60;65;70;80

*bore diameter on request

Size	e	f	g	i	k	l	l1	m	s	sLN	tk	tw	m [kg]
06	3,5	5,5	400	31,5	43	15	22	5	4x4,5	0,2	0,2	0,1	0,53
08	4,3	6,5	400	35	51	20	24	6	4x5,5	0,2	0,3	0,1	0,96
10	5	6,5	400	40,9	60,9	25	27	6	4x6,6	0,2	0,3	0,1	1,84
12	5,5	7,1	400	46,5	70,5	30	30	10	4x6,6	0,3	0,3	0,1	3,24
16	6	8,6	400	53,5	84,5	38	34	10	4x9	0,3	0,4	0,2	5,79
20	7	12,4	400	64,4	103,4	48	40	15	4x9	0,5	0,4	0,2	11,4
25	8	14,9	400	74,9	118,9	55	47	20	4x11	0,5	0,5	0,2	20,4

Dimensions in mm

Keyway to DIN 6885/1-P9

**d J7) predrilled, without slot

***d₁₁ J7 predrilled, without slot

Recommended ISO tolerances for shafts: Up to Ø 50 mm: k₆

Above Ø 50 mm: m₆

Technical data

Flange-mounted clutches

INTORQ 14.105.□□.1.3

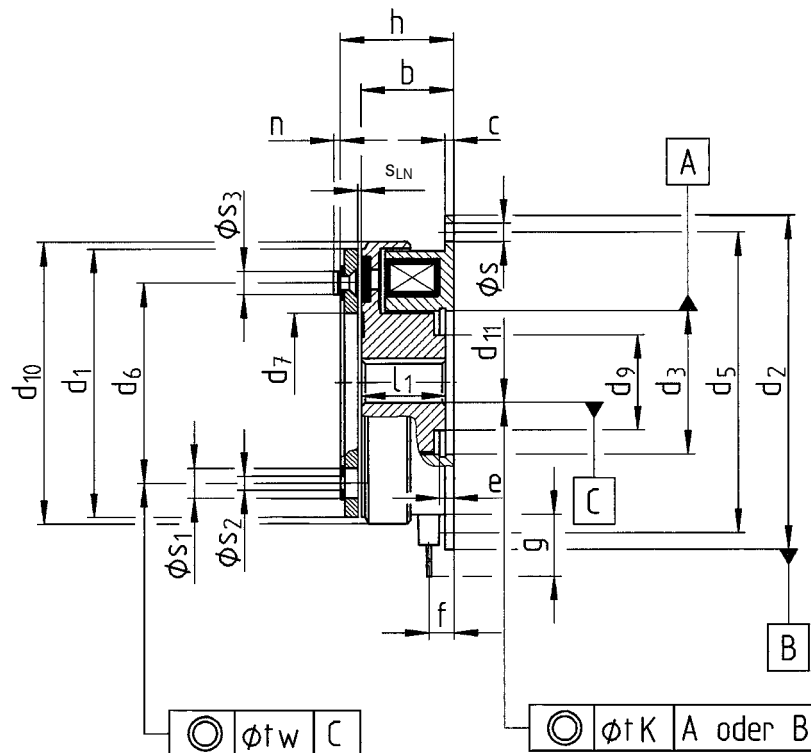

Size	M	b	c	d ₁	d ₂	d ₃	d ₅	d ₆	d ₇	d ₉	d ₁₀	d ₁₁ J7***	d ₁₁ H7
	[Nm]			h8	h9	H8							
06	7,5	24	2	63	80	35	72	46	34,5	23	68	10	10;12;14;15;17
08	15	26,5	2,5	80	100	42	90	60	41,7	28,5	85,5	10	12;14;15;17;19;20;25
10	30	30	3	100	125	52	112	76	51,5	40	107	14	15;17;19*;20;22;24;25;28*;30
12	60	33,5	3,5	125	150	62	137	95	61,5	45	134,3	14	20;24;25;28*;30;35;40
16	120	37,5	4	160	190	80	175	120	79,5	62	170	20	25;28;30;35;38*;40;45;50
20	240	44	5	200	230	100	215	158	99,5	77	214,3	25	35;38;40;42*;45;50;55;60;65
25	480	51	6	250	290	125	270	210	124,5	100	266,5	25	40;45*;50*;55*;60;65;70;80

*bore diameter on request

Size	e	f	g	h	l1	n	s	s ₁	s ₂	s ₃	s _{LN}	t _k	t _w	m [kg]
06	3,5	5,5	400	28	22	1,4	4x4,5	3x6,3	3x3,1	3x5,5	0,2	0,2	0,1	0,49
08	4,3	6,5	400	31	24	1,7	4x5,5	3x8	3x4,1	3x7	0,2	0,3	0,1	0,88
10	5	6,5	400	35,9	27	2,1	4x6,6	3x10,5	3x5,15	3x9	0,2	0,3	0,1	1,68
12	5,5	7,1	400	40,5	30	2,5	4x6,6	3x12	3x6,1	3x10	0,3	0,3	0,1	2,95
16	6	8,6	400	46,5	34	3	4x9	3x15	3x8,2	3x13	0,3	0,4	0,2	5,49
20	7	12,4	400	55,4	40	4	4x9	3x18	3x10,2	3x16	0,5	0,4	0,2	10,2
25	8	14,9	400	63,9	47	4,3	4x11	4x22	4x12,2	4x20	0,5	0,5	0,2	18,7

Dimensions in mm

Keyway to DIN 6885/1-P9

***d₁₁ J7 predrilled, without slot

Recommended ISO tolerances for shafts: Up to Ø 50 mm: k₆
Above Ø 50 mm: m₆

Technical data

Shaft-mounted clutches INTORQ 14.105.□□.3.1

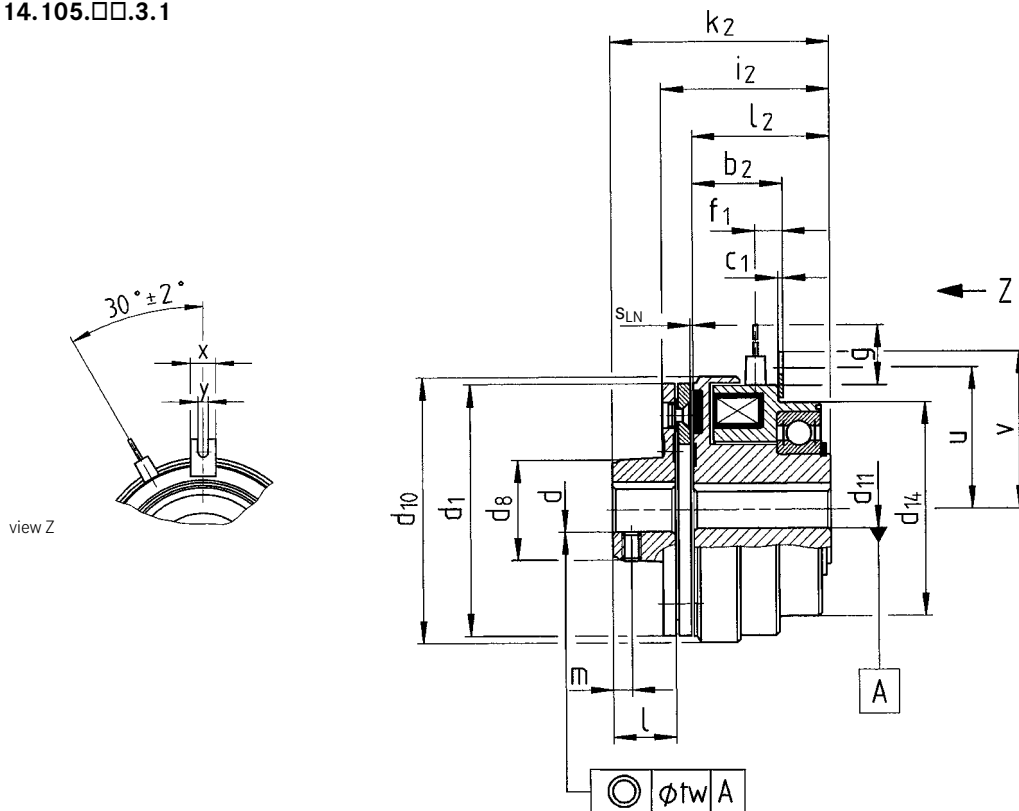

Size	M [Nm]	b ₂	c ₁	d J7**	d H7	d ₁ h8	d ₈	d ₁₀	d ₁₁ J7***	d ₁₁ H7	d ₁₄	f ₁	g
06	7,5	26	1,5	10	10;12;14;15;17	63	27	68	10	10;12;14*;15;17;20*	64	7,7	400
08	15	28	1,5	10	12;14;15;17;19;20	80	32	85,5	10	12;14*;15;17;19;20;25	68	8,2	400
10	30	32,5	2,5	14	15;19;20;24*;25;28*;30	100	42,5	107	14	15;19;20;24;25;28*;30	85	9,2	400
12	60	36	2,5	14	20;24*;25;28*;30;35	125	52	134,3	14	20;24*;25;28;30;35;40	100	9,8	400
16	120	41,7	3,5	20	25;28*;30;35;38*;40;45;50	160	73	170	20	25;28*;30;35;38*;40;50	127	15,2	400
20	240	48,1	3,5	25	30;35;38*;40;42*;45;50;55;60*	200	87	214,3	25	35;38*;40;42*;45;50;55*;60	152,4	16,5	400
25	480	55,2	3,5	25	40;45;50*;55;60;65*;70;80*	250	110	266,5	25	40*;45;50;55*;60*;70*	152,4	19,2	400

*bore diameter on request

Size	i ₂	k ₂	l	l ₂	m	sLN	t _w	u	v	x	y	m [kg]
06	47,5	59	15	40	5	0,2	0,1	36	41	10	4,1	0,83
08	52	68	20	43,5	6	0,2	0,1	45	50	10	4,1	1,28
10	60	80	25	49	6	0,2	0,1	56	60	10	4,1	2,4
12	68	92	30	55	10	0,3	0,1	68,5	72,5	10	4,1	4,15
16	77,5	108,5	38	61,5	10	0,3	0,2	87,5	93,5	20	8,1	7,3
20	93,4	132,4	48	73	15	0,5	0,2	107,5	113,5	20	8,1	14,5
25	103,9	147,9	55	80	20	0,5	0,2	135	141	20	8,1	22,9

Dimensions in mm

Keyway to DIN 6885/1-P9

**d J7 | predrilled, without slot

***d₁₁ J7 predrilled, without slot

Recommended ISO tolerances for shafts: Up to Ø 50 mm: k₆
Above Ø 50 mm: m₆

Technical data

Shaft-mounted clutches INTORQ 14.105.□□.3.3

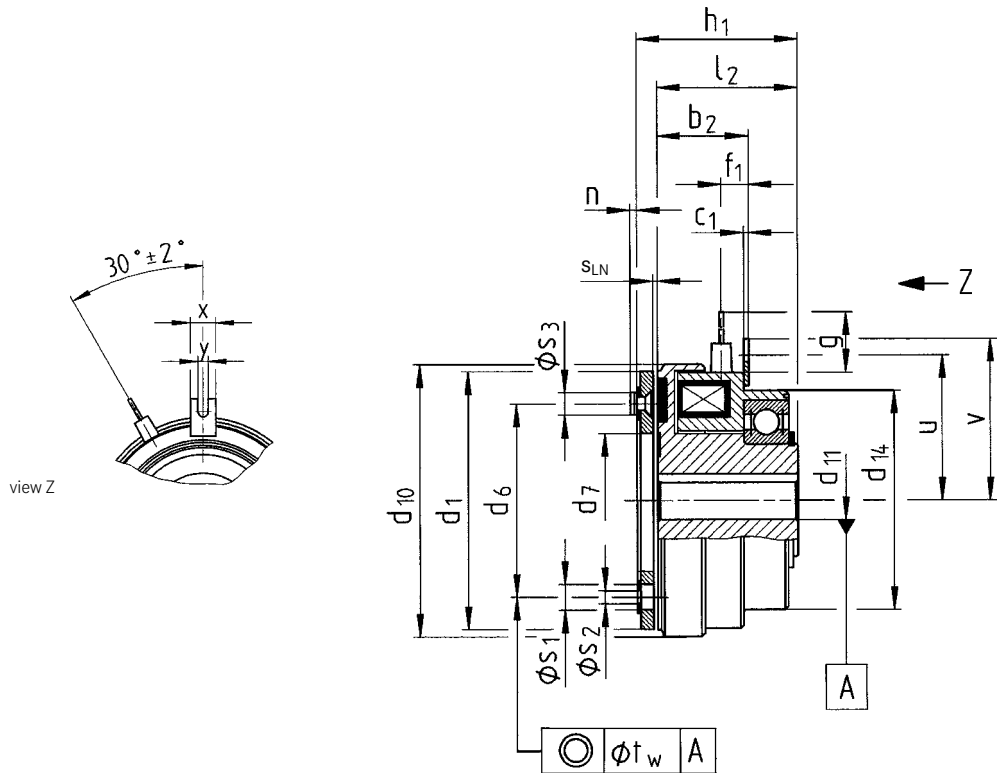

Size	M [Nm]	b2	c1	d1 h8	d6	d7	d10	d11 J7***	d11 H7	d14	f1	g
06	7,5	26	1,5	63	46	34,5	68	10	10;12;14*;15;17;20*	64	7,7	400
08	15	28	1,5	80	60	41,7	85,5	10	12;14*;15;17;19;20;25	68	8,2	400
10	30	32,5	2,5	100	76	51,5	107	14	15;19;20;24;25;28*;30	85	9,2	400
12	60	36	2,5	125	95	61,5	134,3	14	20;24*;25;28;30;35;40	100	9,8	400
16	120	41,7	3,5	160	120	79,5	170	20	25;28*;30;35;38*;40;50	127	15,2	400
20	240	48,1	3,5	200	158	99,5	214,3	25	35;38*;40;42*;45;50;55*;60	152,4	16,5	400
25	480	55,2	3,5	250	210	124,5	266,5	25	40*;45;50;55*;60*;70*	152,4	19,2	400

*bore diameter on request

Size	h1	l2	n	s1	s2	s3	sLN	tw	u	v	x	y	m [kg]
06	44	40	1,4	3x6,3	3x3,1	3x5,5	0,2	0,1	36	41	10	4,1	0,79
08	48	43,5	1,7	3x8	3x4,1	3x7	0,2	0,1	45	50	10	4,1	1,2
10	54,9	49	2,1	3x10,5	3x5,15	3x9	0,2	0,1	56	60	10	4,1	2,24
12	62	55	2,5	3x12	3x6,1	3x10	0,3	0,1	68,5	72,5	10	4,1	3,86
16	70,5	61,5	3	3x15	3x8,2	3x13	0,3	0,2	87,5	93,5	20	8,1	7
20	84,4	73	4	3x18	3x10,2	3x16	0,5	0,2	107,5	113,5	20	8,1	13,3
25	92,9	80	4,3	4x22	4x12,2	4x20	0,5	0,2	135	141	20	8,1	21,2

Dimensions in mm

Keyway to DIN 6885/1-P9

***d11 J7 predrilled, without slot

Recommended ISO tolerances for shafts: Up to Ø 50 mm: k6
Above Ø 50 mm: m6

Technical data

Flange-mounted clutches with flange hub
on bearings INTORQ 14.105.□□.1.5

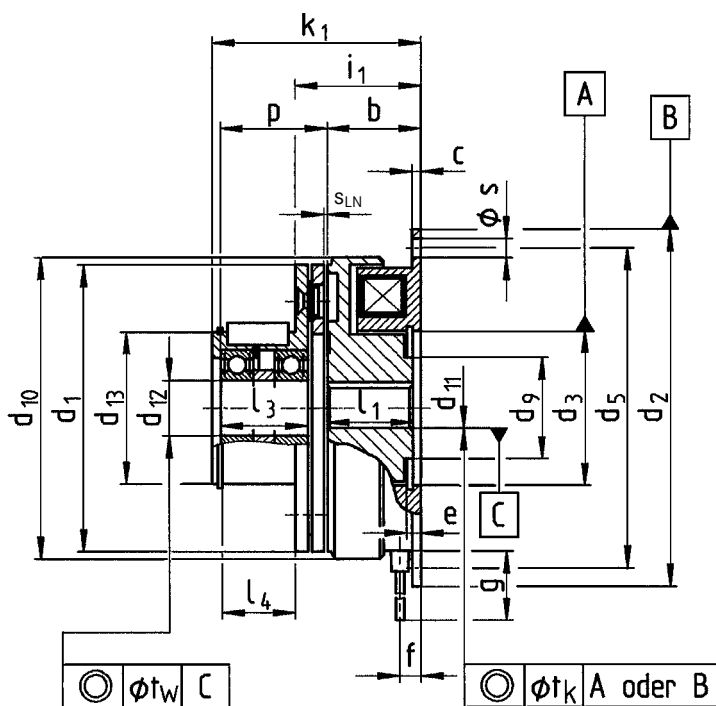

Size	M [Nm]	b	c	d ₁ h8	d ₂ h9	d ₃ H8	d ₅	d ₉	d ₁₀	d ₁₁ J7***	d ₁₁ H7	d ₁₂
06	7,5	24	2	63	80	35	72	23	68	10	10;12;14;15;17	12
08	15	26,5	2,5	80	100	42	90	28,5	85,5	10	12;14;15;17;19;20;25	15
10	30	30	3	100	125	52	112	40	107	14	15;17;19*;20;22;24;25;28*;30	20
12	60	33,5	3,5	125	150	62	137	45	134,3	14	20;24;25;28*;30;35;40	25
16	120	37,5	4	160	190	80	175	62	170	20	25;28;30;35;38*;40;45;50	30
20	240	44	5	200	230	100	215	77	214,3	25	35;38;40;42*;45;50;55;60	40
25	480	51	6	250	290	125	270	100	266,5	25	40;45*;50*;55*;60;65;70	45

*bore diameter on request

Size	d ₁₃ k6	e	f	g	i ₁	k ₁	l ₁	l ₃	l ₄	p	s	SLN	t _k	t _w	m [kg]
06	38	3,5	5,5	400	31	51	22	18	17	22	4x4,5	0,2	0,2	0,1	0,69
08	45	4,3	6,5	400	35	60	24	25	22	30,5	4x5,5	0,2	0,3	0,1	1,24
10	55	5	6,5	400	40,9	70,9	27	31,5	26,5	37,9	4x6,6	0,2	0,3	0,1	2,29
12	64	5,5	7,1	400	46,5	86,5	30	43	36,5	50	4x6,6	0,3	0,3	0,1	3,99
16	75	6	8,6	400	53,5	103,5	34	54	44,5	63	4x9	0,3	0,4	0,2	7,29
20	90	7	12,4	400	65,4	125,4	40	64	53,5	78,4	4x9	0,5	0,4	0,2	13,9
25	115	8	14,9	400	74,9	144,9	47	76	64	88,9	4x11	0,5	0,5	0,2	25,3

Dimensions in mm

Rotor assembly: Keyway to DIN 6885/1-P9

Armature assembly: Keyway to DIN 6885/3-P9

***d₁₁ J7 predrilled, without slot

Recommended ISO tolerances for shafts: Up to Ø 50 mm: k₆
Above Ø 50 mm: m₆

Technical data

Shaft-mounted clutches with flange hub on bearings INTORQ 14.105.□□.3.5

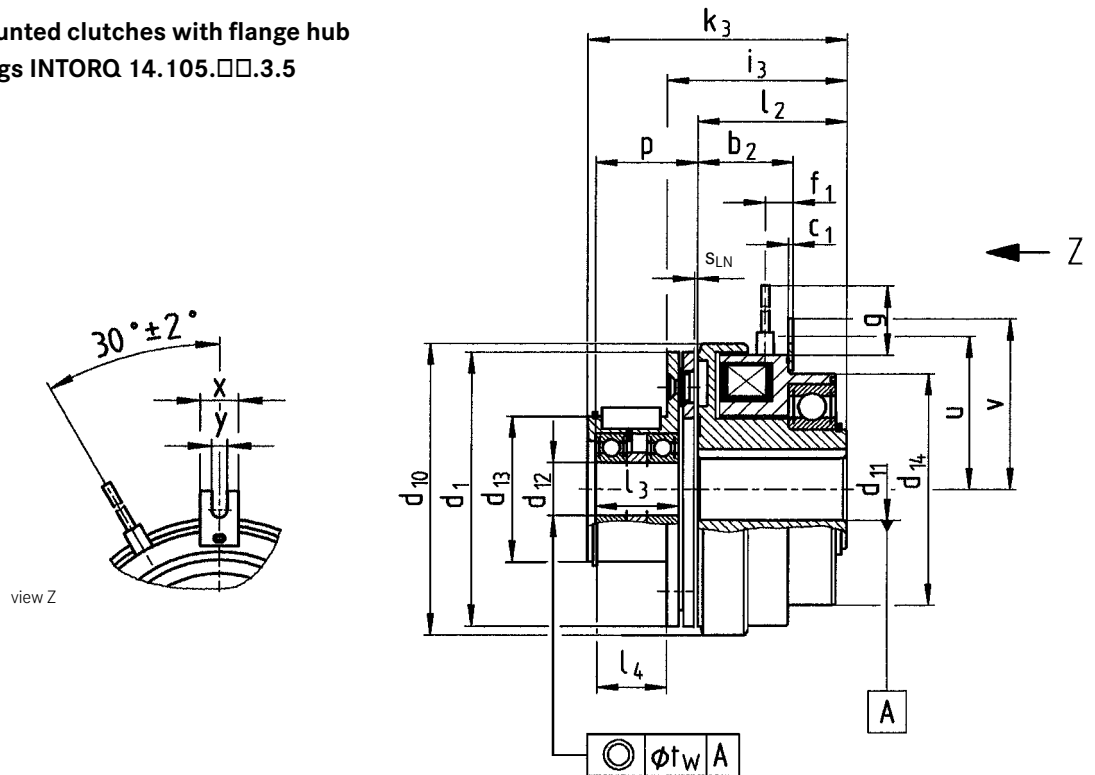

Size	M [Nm]	b ₂	c ₁	d ₁ h8	d ₁₀	d ₁₁ J7***	d ₁₁ H7	d ₁₂
06	7,5	26	1,5	63	68	10	10;12;14*;15;17;20*	12
08	15	28	1,5	80	85,5	10	12;14*;15;17;19;20;25	15
10	30	32,5	2,5	100	107	14	15;19;20;24;25;28*;30	20
12	60	36	2,5	125	134,3	14	20;24*;25;28;30;35;40	25
16	120	41,7	3,5	160	170	20	25;28*;30;35;38*;40;50	30
20	240	48,1	3,5	200	214,3	25	35;38*;40;42*;45;50;55*;60	40
25	480	55,2	3,5	250	266,5	25	40*;45;50;55*;60*;70*	45

*bore diameter on request

Size	d ₁₃ k6	d ₁₄	f ₁	g	i ₃	k ₃	l ₂	l ₃	l ₄	p	s _{LN}	t _w	u	v	x	y	m [kg]
06	38	64	7,7	400	47	67	40	18	17	22	0,2	0,1	36	41	10	4,1	0,99
08	45	68	8,2	400	52	77	43,5	25	22	30,5	0,2	0,1	45	50	10	4,1	1,56
10	55	85	9,2	400	60	90	49	31,5	26,5	37,9	0,2	0,1	56	60	10	4,1	2,85
12	64	100	9,8	400	68	108	55	43	36,5	50	0,3	0,1	68,5	72,5	10	4,1	3,9
16	75	127	15,2	400	77,5	127,5	61,5	54	44,5	63	0,3	0,2	87,5	93,5	20	8,1	8,8
20	90	152,4	16,5	400	94,4	154,4	73	64	53,5	78,4	0,5	0,2	107,5	113,5	20	8,1	17
25	115	152,4	19,2	400	103,9	173,9	80	76	64	88,9	0,5	0,2	135	141	20	8,1	27,8

Dimensions in mm

Rotor assembly: Keyway to DIN 6885/1-P9

Armature assembly: Keyway to DIN 6885/3-P9

***d₁₁ J7 predrilled, without slot

Recommended ISO tolerances for shafts: Up to Ø 50 mm: k₆

Above Ø 50 mm: m₆

Technical data

Electromagnetic brakes INTORQ 14.115.□□.1.1

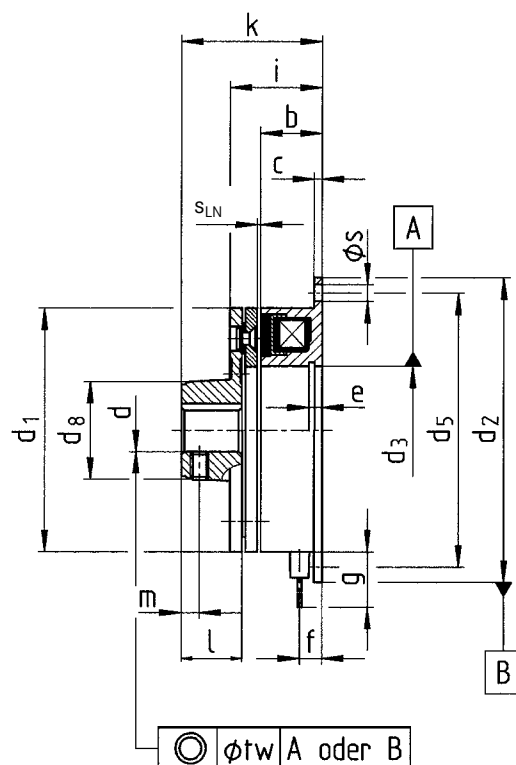

Size	M [Nm]	b	c	d J7**	d H7	d ₁ h8	d ₂ h9	d ₃ H8	d ₅	d ₈	e
06	7,5	18	2	10	10;12;14;15;17	63	80	35	72	27	3,5
08	15	20	2,5	10	12;14;15;17;19;20	80	100	42	90	32	4,3
10	30	22	3	14	15;19;20;24*;25;28*;30	100	125	52	112	42,5	5
12	60	24	3,5	14	20;24*;25;28*;30;35	125	150	62	137	52	5,5
16	120	26	4	20	25;28*;30;35;38*;40;45;50	160	190	80	175	73	6
20	240	30	5	25	30;35;38*;40;42*;45;50;55;60*	200	230	100	215	87	7
25	480	35	6	25	40;45;50*;55;60;65*;70;80*	250	290	125	270	110	8

*bore diameter on request

Size	f	g	i	k	l	m	s	s _{LN}	t _w	m [kg]
06	5,5	400	25,5	37	15	5	4x4,5	0,2	0,16	0,32
08	6,5	400	28,5	44,5	20	6	4x5,5	0,2	0,16	0,59
10	6,5	400	32,9	52,9	25	6	4x6,6	0,2	0,16	1,11
12	7,1	400	37	61	30	10	4x6,6	0,3	0,2	2
16	8,6	400	42	73	38	10	4x9	0,3	0,2	3,5
20	12,4	400	50,4	89,4	48	15	4x9	0,5	0,2	7,05
25	14,9	400	58,9	102,9	55	20	4x11	0,5	0,3	12,7

Dimensions in mm

Keyway to DIN 6885/1-P9

**d J7) predrilled, without slot

Recommended ISO tolerances for shafts: Up to ϕ 50 mm: k₆

Above ϕ 50 mm: m₆

Technical data

Electromagnetic brakes INTORQ 14.115.□□.1.2 and INTORQ 14.115.□□.1.3

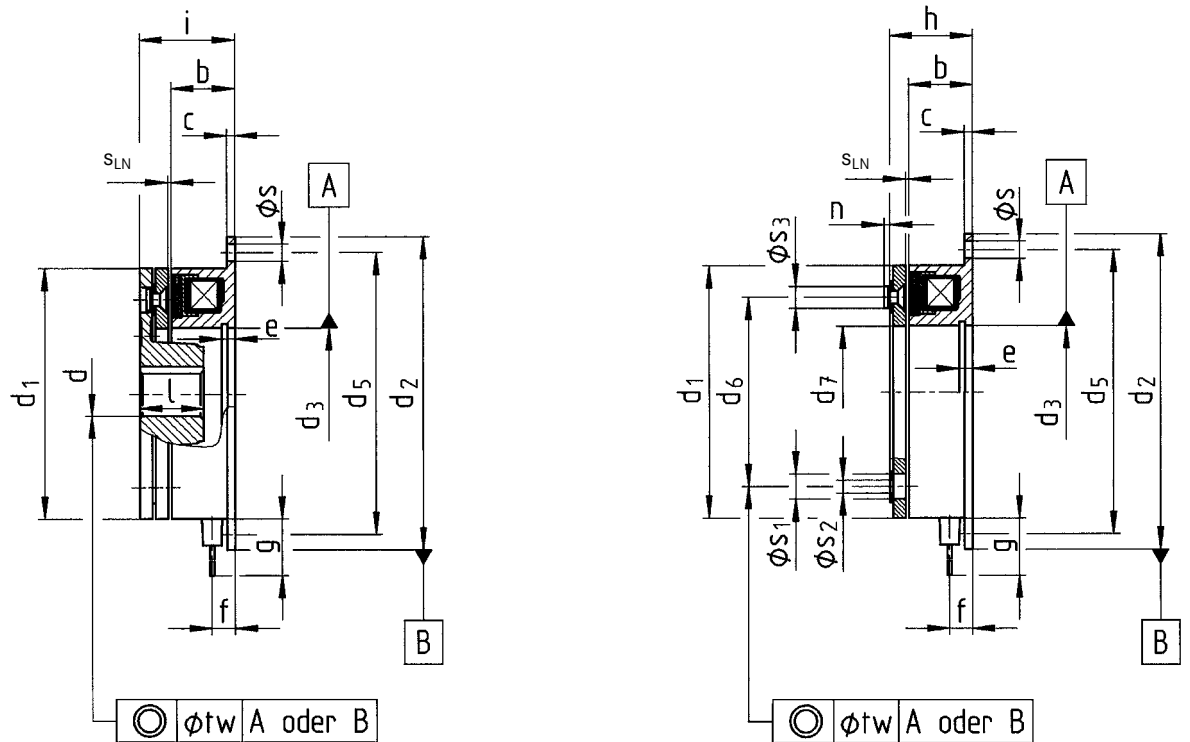

Size	M [Nm]	b	c	d J7**	d H7	d ₁ h8	d ₂ h9	d ₃ H8	d ₅	d ₆	d ₇	e
06	7,5	18	2	10	10;12;14;15;17	63	80	35	72	46	34,5	3,5
08	15	20	2,5	10	12;14;15;17;19;20	80	100	42	90	60	41,7	4,3
10	30	22	3	14	15;19;20;24*;25;28*;30	100	125	52	112	76	51,5	5
12	60	24	3,5	14	20;24*;25;28*;30;35	125	150	62	137	95	61,5	5,5
16	120	26	4	20	25;28*;30;35;38*;40;45;50	160	190	80	175	120	79,5	6
20	240	30	5	25	30;35;38*;40;42*;45;50;55;60*	200	230	100	215	158	99,5	7
25	480	35	6	25	40;45;50*;55;60;65*;70;80*	250	290	125	270	210	124,5	8

*bore diameter on request

Size	f	g	h	i	l	n	s	s1	s2	s3	s _{LN}	t _w	m [kg]	1,2	1,3
06	5,5	400	22	25,5	15	1,4	4x4,5	3x6,3	3x3,1	3x5,5	0,2	0,16	0,32	0,28	
08	6,5	400	24,5	28,5	20	1,7	4x5,5	3x8	3x4,1	3x7	0,2	0,16	0,59	0,51	
10	6,5	400	27,9	32,9	25	2,1	4x6,6	3x10,5	3x5,15	3x9	0,2	0,16	1,11	0,95	
12	7,1	400	31	37	30	2,5	4x6,6	3x12	3x6,1	3x10	0,3	0,2	2	1,71	
16	8,6	400	35	42	38	3	4x9	3x15	3x8,2	3x13	0,3	0,2	3,5	3,2	
20	12,4	400	41,4	50,4	48	4	4x9	3x18	3x10,2	3x16	0,5	0,2	7,05	5,85	
25	14,9	400	47,9	58,9	55	4,3	4x11	4x22	4x12,2	4x20	0,5	0,3	12,7	11	

▮ Dimensions in mm

▮ Keyway to DIN 6885/1-P9

▮ **d J7) predrilled, without slot

▮ Recommended ISO tolerances for shafts: Up to Ø 50 mm: k₆

Above Ø 50 mm: m₆

Accessories

Transformer switch TS 48 INTORQ 14.610.11.048

Features

- Transformer switch TS 48 contains the entire current supply for a 24 V DC coil with transformer, rectifier and switching transistor with suppressor circuit
- A transistor is used for switching; there is no contact wear
- The high induced voltage enables the release times indicated in the catalogue for DC switching to be achieved.

Dimensions

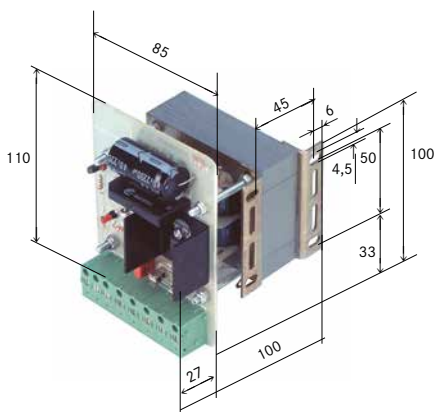

Applications

- Current supply for 24 V coils on AC mains
- Normal excitation with rated coil voltage
- Switching of coil current via PLC, proximity switch, contacts, control voltage 5 – 24 V

Technical data

Normal excitation	24 V
Mains voltage	230 V, 50/60 Hz
Coil voltage	24 V =
Max. coil load	50 W

Max. operating frequency:

Up to 35 W	5 switching operations/s
Up to 50 W	2 switching operations/s

Connectable coils	1 x
Switching of coil current:	Transistor
The entire switching operation is potential-free.	
Control current at 24 V	Approx. 1 mA
Weight:	1.5 kg

Connection examples

Control via PLC

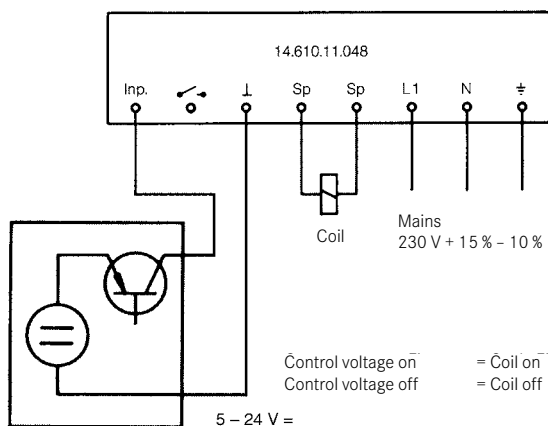

Control via contact

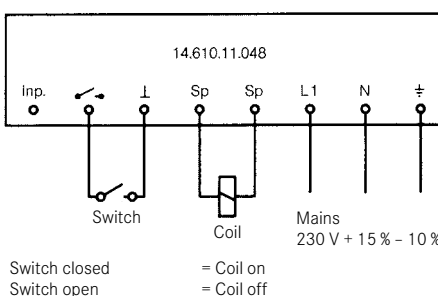

Control via 2-wire proximity switch

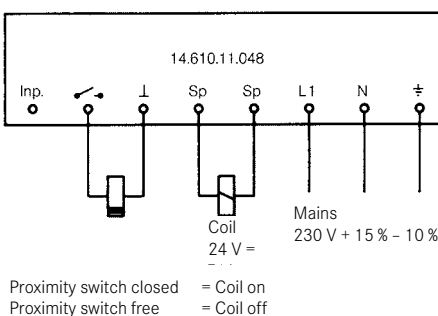

Accessories

Spark suppressor INTORQ 14.198.00.01/02/03

Features

The INTORQ spark suppressor protects the coil and contact against impermissibly high induced voltages with DC switching. In the absence of a suppressor circuit, the induced voltage may exceed the permissible values specified in VDE 0580 and cause coils to fail.

The spark suppressor comprises an induction-free pulse capacitor which takes up the high-speed current peaks which occur during switching. This significantly reduces the spark at the contact (contact wear).

Application

Suppressor circuit for coil and contact:

- Limitation of induced voltage at coils
- Spark suppression at switching contacts
- Increase in service life of coils and contacts

Dimensions

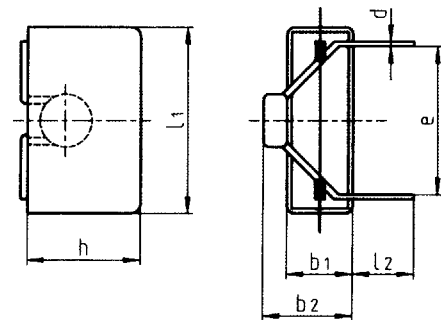

Technical data

INTORQ	Coil voltage	Max. mains voltage	Max. coil power	Capacitor voltage	b ₁	b ₂ approx.	d	e approx.	h	l ₁	l ₂ approx.	m [g]
14.198.00.01	24 V - 50 V	60 V~	110 W	250 V-	8.5	12.5	0.7	22.5	18.5	26.5	25	7
14.198.00.02	50 V - 120 V	250 V~	110 W	630 V-	15	21	0.7	37.5	26	41.5	20	22
14.198.00.03	120 V - 200 V	400 V~	110 W	1000 V-	13	20	0.7	37.5	24	41.5	15	17
14.198.00.04	200 V - 250 V	555 V~	110 W	1000 V-	13	20	0.7	37.5	24	41.5	15	10

Connection examples

Parallel to contact

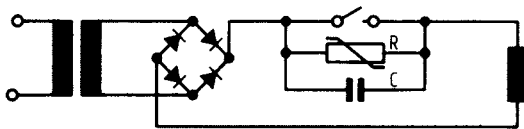

Parallel to coil

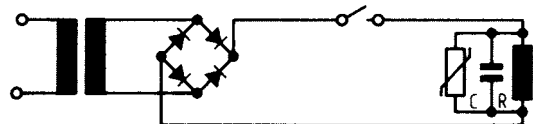

Accessories

SEGC high-speed switchgear INTORQ 14.611

Features

INTORQ-SEGC high-speed switchgear is used for the high-speed excitation of DC voltage coils and reduces engagement times to as little as 10% of the values indicated in the Technical data.

Switching is wear-free via semiconductors. This makes simple activation with auxiliary contacts, control voltages or proximity switches possible. Following overexcitation, the coil operating voltage is automatically reduced to the holding voltage.

For more detailed technical information, see the "Electronic switchgear" manual.

Application

High-speed excitation of DC voltage coils with a rated voltage of 24 to 205 V.

You can use INTORQ-SEGC high-speed switchgear on electromagnetic clutches/electromagnetic brakes to achieve:

- Shorter acceleration/deceleration times
- Higher operating frequencies
- Improved operating accuracy
- Reduced wear
- Improved stopping accuracy

SEGC-Electronic INTORQ 14.611.12.□□□

- Structure: 220 x 150 mm PCB
- Connection via 10-pin terminal strip
- Max. connected load 100 W
- Required accessories: MP capacitor



SEGC-Europe INTORQ 14.611.14(16).□□□

- In terms of electronics, design is identical to that of the SEGC-Electronic
- Constructed with European standard board dimensions 160 x 100 mm
- Connection via 31-pin DIN plug connector
- Max. connected load 40 W/100 W
- Required accessories: MP capacitor, plug-in rack



General information for assembly

- ▮ Assembly and maintenance work may only be carried out by specialist personnel with appropriate training, and only in accordance with the specifications in the Operating and Mounting Instructions.
- ▮ Grease or oil on friction surfaces reduces the drive/braking torque. For this reason, friction surfaces must be kept free of grease and oil.
- ▮ The regulations set out in the machine safety law for rotary drive elements must be observed.
- ▮ If units with large diameters are switched in at high speeds, the high relative speed at the friction surfaces can cause sparking. The use of a suitable cover is recommended.
- ▮ The air gap S_{Lue} must be checked at regular intervals and readjusted no later than $2.5 \times S_{Lue}$ (see Technical data).

Screws, screw locking element and tapped hole for fastening type 3 armature assembly

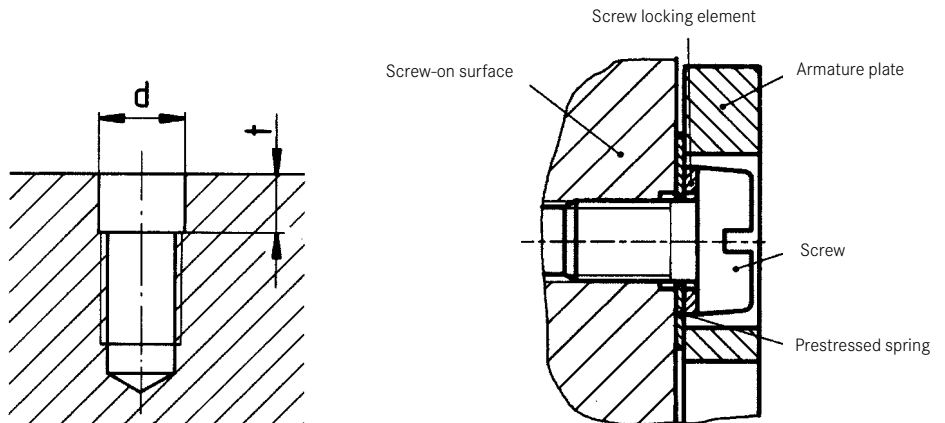

Size	Screws	DIN	Schnorr screw locking element *	Ø d [mm]	t [mm]
06	M 3 x 8	DIN 84	Schnorr lock washer 3.0	3.1	0.8
08	M 4 x 10	DIN 84	Schnorr lock washer 4.0	4.1	1.0
10	M 5 x 12	DIN 6912	Schnorr lock washer 5.0	5.1	3.5
12	M 6 x 16	DIN 7984	Schnorr lock washer 6.0	6.1	2.8
16	M 8 x 20	DIN 7984	Schnorr lock washer 8.0	8.2	3.5
20	M 10 x 25	DIN 7984	Schnorr lock washer 10	10.2	3.5
25	M 12 x 25	DIN 7984	Schnorr lock washer 12	12.2	3.8

* Available from:

Adolf Schnorr GmbH & Co. KG
 PO Box 60 01 62 · 71050 Sindelfingen, Germany
 Tel. +49 (0) 70 31 30 20 · Fax +49 (0) 70 31 38 26 00

Setting standards in the market, worldwide

We are available to our customers at all times and in all locations. Major customers and projects are supported directly by our Key Account Sales Team at our HQ in Aerzen (Germany) or by our locations in Shanghai (China), Atlanta (USA) and Pune (India).

In addition to this, we work with a global network of local trading partners and cooperate with Lenze's global sales organisation.

Please send service requests directly to your local sales partner or to our HQ in Aerzen, Germany:

E-mail service@intorq.de

Tel: +49 5154 70534-444

Fax: +49 5154 70534-200

You can find more information on our products, as well as catalogues and operating instructions available for download, on our website at www.intorq.de



INTORQ GmbH & Co. KG

Postfach 1103
D-31849 Aerzen, Germany

Wülmser Weg 5
D-31855 Aerzen, Germany

Tel: +49 5154 70534-0
Fax: +49 5154 70534-200
E-mail info@intorq.de

INTORQ (Shanghai) CO., LTD

China

No. 600, Xin Yuan Nan Road,
Building No. 6 / Zone B
Nìcheng town, Pudong
Shanghai, China 201306

Tel: +86 21 20363-810
Fax: +86 21 20363-805
E-mail info@cn.intorq.com

INTORQ US INC.

USA

300 Lake Ridge Drive SE
Smyrna, GA 30082, USA

Tel: +1 678 236-0555
Fax: +1 678 309-1157
E-mail info@us.intorq.com

INTORQ India Pvt. Ltd.

India

Plot No. E-7/3, Chakan
Industrial Area, Phase 3,
Nìghojje, Taluka-Khed,
Pune, 410501 Maharashtra

Tel: +91 21 3562-5500
E-mail info@intorq.in

www.intorq.com